

December 2022

Enjoy the Music.com[®]

Esoteric N-05XD DAC, Preamplifier, Headamp And Music Streamer Review

The new Japanese sound.

Review By Ran Xiang



The Esoteric sound has normally been deemed as rather representative of the so-called Japanese sound, which is to some nuanced, introverted, controlled and detail-oriented, and to others thin-sounding, sharp, lacking body and bass shy. Yet Esoteric's first self-developed Master Discrete DAC has definitely revised the stereotype of the Japanese sound which was criticized as sounding like a radish (think about the light flavor as well as the shape of a radish with a big head on the top and a thin bottom end).

N-05XD has inherited the traditional focus on details and nuances, yet it is much fuller, more musical, and analog sounding compared to their previous lineups utilizing AKM chips. Reproducing the full sound quality of the original masters, the N-05XD represents a new frontier in network DAC/preamps, therefore it is not an exaggeration to say that the N-05XD has evolved the stereotype of the Japanese sound.

The Minimalist Approach

The Esoteric N-05XD follows the current trend towards all-in-one designs as a digital-to-analog converter (DAC), Roon-ready streamer, pre-amplifier, and headphone amplifier combined together as a single unit. This all-in-one design gives an unparalleled user experience where I can control everything using one hand or one remote (which in the case of N-05XD is well built with one side to control the network/DAC and the other side to control a compatible Esoteric

SACD player and amp). It also saves me the trouble of cable matching between the various source components, as well as the maintenance of all the various components on a daily basis. Furthermore, it makes my life much easier should I need to move nationally and internationally.



On the Build And Finish

For someone who doesn't normally care about the look of HiFi products, I must admit it is probably the first time that I have really appreciated the aesthetics of a piece of equipment. While the shape of N-05XD is relatively plain, the design manages to be neat, elegant, and sexy. It is also worth mentioning that N-05XD is the only unit that Esoteric currently offers the option of black color as the N-05XD B Black. Specifically, it is not as dark black, but more of a grayish black, which matches perfectly with other components in my system aesthetically. For that minimalist look and second-to-none build and finish, I won't be surprised if there are folks who will buy it for the physical appearance alone.

On the Master Discrete DAC

While Esoteric has earned a huge reputation for its CD transports worldwide, its AKM-based DACs never seem to get much attention. The N-05XD uses Esoteric's newest proprietary Master Discrete DACs, passed down from their flagship Grandioso D1X Mono-block D/A Converter, bringing it up to a whole new level of performance.

Technically, Esoteric's Discrete DAC features a sophisticated discrete circuit design with Delta Sigma ($\Delta\Sigma$) modulation, rather than an R-2R Ladder design, however, Esoteric's Master Discrete DAC shares the sonic traits of both a full-sounding analog R-2R and the technical capabilities associated with chip DACs. It is a combination of Esoteric's exclusive Delta Sigma ($\Delta\Sigma$) modulator, and separate custom-coded FPGA (Field-Programmable Gate Array) digital processing algorithms developed for each step in the conversion process that allows it to achieve this.



"The fundamental goal in the development of the Master Sound Discrete DAC was to achieve an accurate, full-bodied reproduction of all the vibrancy and energy of music. Music is infused with all the passion that a performer brings to a passage, with instantaneous and explosive energy." — Esoteric

Due to the quality of the internal components of the N-05XD, it is really not necessary to add any DDC (Digital to Digital Converter) or jitter purifier, nor is there a need to add isolation or damping materials, in that their stock feet and board at the top of the chassis do an excellent job in this regard.

On the Streamer

I mostly enjoy listening to music via the built-in streamer via Roon which is designed in collaboration with Lumin. It is worth noting that the streamer section is powered by a linear power supply (LPS), quite the value as a Lumin streamer with LPS that can cost \$7500. The N-05XD is also Roon ready, and streaming via Roon made the sound slightly softer, thinner, yet notably more detailed and nuanced with better stereo imaging. I never liked the Roon streaming service before due to its tonality, therefore it is safe to say the N-05XD has changed the way I listen to music. While there might be room for additional sonic improvements with better sources, the built-in streamer is, by all means, high performing.



On The Headphone Amp

As the first headphone amp from Esoteric, the N-05XD has totally exceeded my expectations. It is quiet enough to drive my most sensitive IEMs, yet powerful enough to drive my Sennheiser

HD800s and HIFIMAN SUSVARA. I really enjoy the maximized soundstage that I have never heard from my Westone W80, and Audeze iSINE 10. The focused, close to ear vocals as well as the giant 3D stage gives my HD800s the vibes of a Sony MDR-R10 Bass Light version. That centric midrange can largely complement gear regarded as recessed in the vocal and mid-range, for instance, the HD800s and 64 Audio Tia Fourte. Similar to the Chord DAVE, I feel the transparency and clarity really shine when using the built-in headphone amplifier.

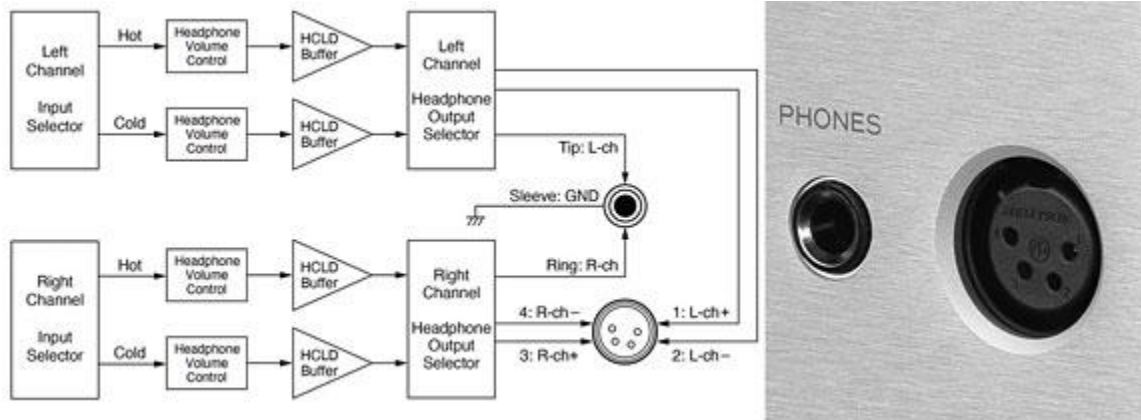

On The Preamplifier

The preamp section of N-05XD employed a complex balanced design, Esoteric-QVCS (Quad Volume Control System), controlling the left and right channels separately to ensure perfect channel matching and superior sound quality. In my experience with the N-05XD, I didn't hear any sound degradation when enabling the preamp, which says a lot about the quality. I even experimented using the N-05XD as a pure preamplifier with my other DACs. I found enhanced clarity, separation, stage height, and depth, as well as delicacy.



The N-05XD also has a top-notch volume knob, which feels smooth and premium. As Esoteric says, "*Just a touch of its volume knob clearly reveals this quality in its most exquisite form and promises the fullest and most satisfying enjoyment of Esoteric's pure signature sound.*"

On the Master Clock

I was once told by another Esoteric N-05XD owner that after he tried the Cybershaft OP21A master clock, he will never buy a DAC that can't accept an external master clock. He added that with a master clock is like 4k TV and without is like 1080P. Personally speaking, adding the musical-sounding Mutec REF10 master clock to the N-05XD with Boomsnang clock cable makes an instant impact, bringing the sound more life. Everything is more. More texture, and more beef to the music. It is more solid, fuller, more natural, and analog with better control, dynamics, and more authoritative low ends. All the elements in the music sound as if being woken up by the master clock. Acknowledged, different master clocks, as well as clock cables, vary in their house sound. Yet with notably enhanced temporal and spatial accuracy, I guess I can no longer go without them. No A/B comparison is needed as the difference is not minor.



Despite the ongoing debate over the phase noise and jitter generated by the increased distance between the DAC and the master clock, as well as the role of the clocks in DACs for playback and the role in recording and mastering equipment, I would always refer to my first-hand experiments to gauge before jumping to any conclusion, because HiFi is in practice and the proof is in the ears, and in the case of the N-05XD, (in my opinion) it is a must.

On The Listening Impression

To ensure that any external sources, amplifiers, master clocks, and cables wouldn't change the sound, all listening impressions were made using the Esoteric N-05XD's built-in headphone amplifier and built-in streamer via Roon in order to avoid, as much as possible, any variance. The headphone used in the test is the Sennheiser HD800s, the soundstage king, via the balanced 4-pin XLR output.

In order to gauge the macro and micro details, I used the highly regarded classical album "Track 24, "Caprices for violin, Op.1, MS.25", showcases the outstanding control of N-05XD. No matter how fast the violin was being played, everything sounded effortless and in control, in a way that didn't feel compressed or forced. Even in the super-high registers, there was no sign of digital glare, hash, or fatigue.

Thanks to the realistic tonality and texture of the instruments as well as the massive sense of space, live performances have never before sounded as pleasant to my ears as they did through the Esoteric. Playing "Trilogy Suit" from the album " feels as if I was literally at the concert. Clapping from the audience has never sounded this real and euphoric. Even the cough and noises from the background could be not only located but delineated as to their physical shape. It was funny, you could feel how much a guy in the background was annoyed by other loud audience members, by the way he was shushing at them.

Meanwhile, I never lost the palpable vocals in that three-dimensional room. On the contrary, there is a strong focus on the vocals, making it a perfect match for vocal-centric music as they feel so close to your ears that you can feel the shape of the lips and mouth of the singer. Listening to the track "Moses Don't Get Lost" by Bessie Jones, I felt like I was surrounded by

the choir of female and male island singers, involuntarily tapping my toes to the beat along with them.

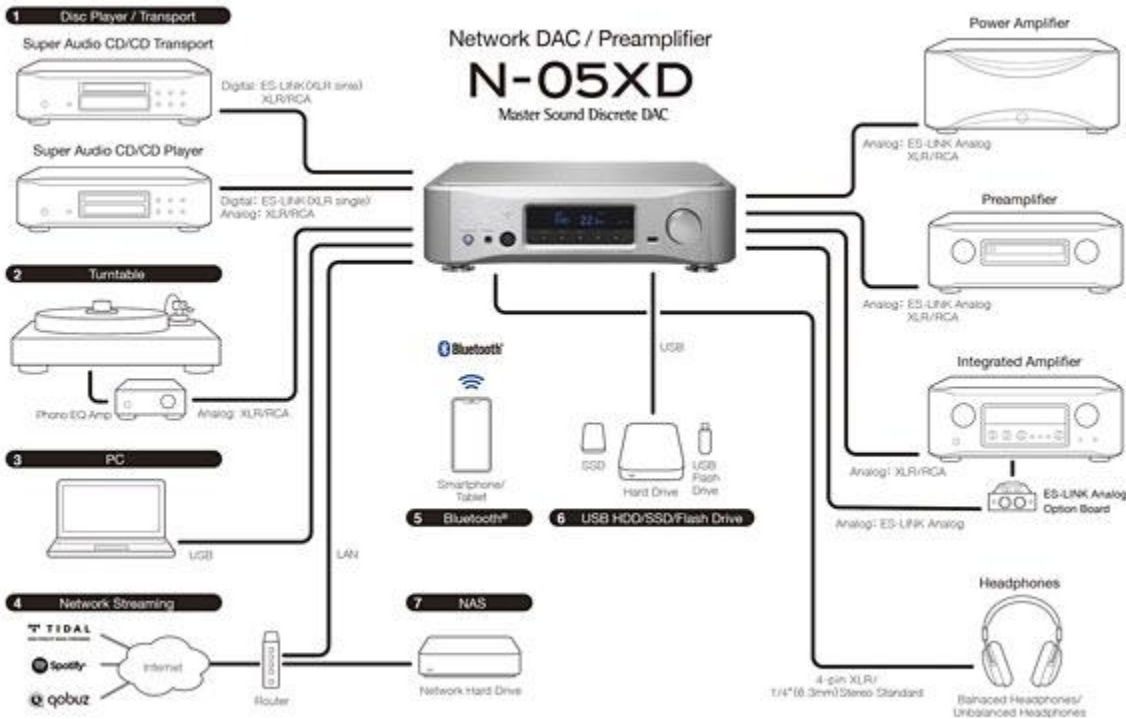

Casey Abrams' Robot Lovers manifested the excellent separation between the singer and various instruments in the band, positioned accurately and clearly. Any movement and motion of the singer could be easily noticed by the continual change of his location on the stage.

As for the lows, the N-05XD is not a bass monster that can slam or rumble aggressively as Mojo Mystique XSE, and RocknaWavedream, yet the bottom end is still present. As evidenced by the track "Bossa Nova U.S.A." by Dave Brubeck and The Dave Brubeck Quartet, the attack from the jazz drum set is strong and intimidating.



Closing: The Golden Mean Of Two Worlds

The golden mean, as the essence of oriental Confucianism, has been manifested in the Esoteric N-05 XD. Its Master Discrete DAC is the epitome of perfectly balancing the digital and analog realms. It is more realistic and musical compared to typical chip DACs, while more nuanced and layered than fuller-sounding analog DACs, making it versatile enough for most genres with

great potential for further upgrades. It has inherited the Japanese sound while at the same time succeeding in getting rid of the thin, cold, and bland radish-like characteristics.



Adding a master clock, a higher quality source, and an amplifier will definitely better fill the enormous stage with even more body, soul, dynamics, and life. After all, the highlight of the N-05XD is still its Master Discrete DAC. The forte of the DAC is its massive stage size and the natural sound of the instrumental textures and tonality. It is so good that it managed to alter the genres of music that I normally listen to, as I seldom listen to classical or live recordings. Esoteric's corporate philosophy has been the reproduction of the original sound performed by musicians in a studio or concert hall, and the N-05XD really delivers it.

At the asking price of \$11,000, the N-05XD has an outstanding DAC that it shares with Esoteric's flagship, a good streamer with a separate linear power supply, and a headphone amp that could adequately drive all headphones and IEMs along with a well-built preamp. It is no wonder that it has been crowned the best product of the year by many. Welcome to the age of the new Esoteric sound, and welcome to the age of the new Japanese sound.

Specifications

Type: DAC, preamplifier, headphone amplifier, and streamer

Digital Input : Two RCA S/PDIF (PCM 24bit/ 192 kHz ; DSD 2.8 MHz/ DoP)

AES/ EBU x 1 (PCM 24bit/192 kHz ; DSD 2.8 MHz/ DoP)

Coax x 2 (PCM 24bit/ 192 kHz ; DSD 2.8 MHz, DoP)

USB type B x 1 (PCM 32bit/ 384 kHz ; DSD 22.5 MHz)

USB type A x 2 (PCM 32bit/ 384 kHz ; DSD 22.5 MHz)

Bluetooth 4.0 (A2DP, AVRCP, LDAC, LHDC, aptX HD audio, aptX audio, AAC, SBC)

Analogue Input: RCA x 1 ; XLR x 1

Analogue Output: RCA x 1 ; XLR/ ESL-A x 1 ; ESL-A Pre Out x 1

Headphone Output: 4-pin XLR x 1 ; 6.3mm phono jack x1

Clock Input: BNC x1 (10MHz \pm 10ppm)

Size: 445 x 131 x 377 mm (WxHxD)

Weight : 13.8 kgs.

Price: \$11,000

Manufacturer

Esoteric

Website: Esoteric.jp

USA Distributor

11 Trading Company, LLC

3502 Woodview Trace #200

Indianapolis, IN 46268

Website: 1tradingcompany.com



HEADPHONE.GURU

Check Out Headphone.Guru
See many great reviews by *Headphone.Guru* at this link.